

◆ Feature

1. Dual function for EMI and ESD
2. Compact size for EIA 0402 and 0603
3. ESD protection for IEC61000-4-2 Level 4
4. Fixed capacitance suitable for high-speed I/O port transient voltage protection
5. RoHS Compliant



◆ Application

Applications for I/O Port for Mother Board and Notebook (RS232, USB, PS2, VGA, Audio), Set-Top Box, MP3 Players, DVD Players, and Docking System etc.

◆ How to Order

VPORT 0402 100 M V05 □
 (1) (2) (3) (4) (5) (6)

- (1) Series Type: V — Over Voltage Protection
 PORT — EMI Protection for I/O Port
- (2) Chip Size(EIA) : 0402 / 0603
- (3) Capacitance : Value—XXx10^N→XXN
 ex: 10pF=10x10⁰→100
- (4) Capacitance Tolerance : M = ±20%
- (5) Working Voltage: 0402→5V
 0603→5V/12V
- (6) Suffix for Special Code

◆ Dimension

Unit: mm

Size EIA (EIAJ)	0402 (1005)	0603 (1608)
L	1.00±0.15	1.60±0.20
W	0.50±0.10	0.80±0.20
T	0.50±0.10	0.80±0.20
C	0.25±0.15	0.30±0.20

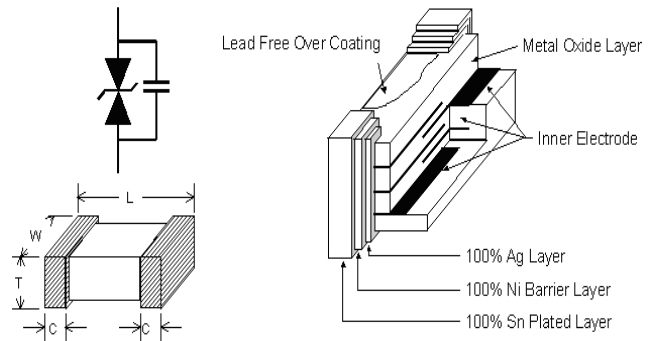

◆ Specification

General Characteristics (25±5°C)

*Description	A	B	C	D	E	F	G					
Part Number	Operating Voltage (V _{DC})	Leakage Current (I _L)	Capacitance (C _p)	Clamping Voltage (V _c)	Capacitance Tolerance	Dissipation Factor	Temperature Characteristic					
VPOR 0402 XXXX V05 Series												
VPOR0402100MV05	5V	<15μA	10	34	M :±20%	4.0%max.	ΔC:+15%/-15%					
VPOR0402220MV05			22	30								
VPOR0402330MV05			33	28								
VPOR0402470MV05			47	26								
VPOR0402101MV05			100	23								
VPOR0402151MV05			150	22								
VPOR0402181MV05			180	22								
VPOR0402221MV05			220	20								
VPOR 0603 XXXX V05 Series												
VPOR0603100MV05	5V	<15μA	10	34	M :±20%	4.0%max.	ΔC:+15%/-15%					
VPOR0603220MV05			22	30								
VPOR0603330MV05			33	28								
VPOR0603470MV05			47	26								
VPOR0603101MV05			100	23								
VPOR0603151MV05			150	22								
VPOR0603181MV05			180	22								
VPOR0603221MV05			220	20								
VPOR0603331MV05			330	19								
VPOR0603471MV05			470	19								
VPOR0603102MV05			1000	19								
VPOR 0603 XXXX V12 Series												
VPOR0603220MV12			12V	<15μA				22	42	M :±20%	4.0%max.	ΔC:+15%/-15%
VPOR0603330MV12	33	40										
VPOR0603470MV12	47	38										
VPOR0603151MV12	150	35										
VPOR0603181MV12	180	31										
VPOR0603331MV12	330	30										

*Description

Item	Description
A	Max. Continuous Operating Voltage (V_{DC}).
B	Leakage Current (I_L). Measured at rated continuous operating voltage.
C	Capacitance (C_p). The test condition is 1KHz(≥ 100 pF)/1MHz (< 100 pF) 1Vrms $\pm 10\%$ and the environment temperature is 25 $\pm 2^\circ$ C.
D	Max. Clamping voltage (V_c). Maximum peak current across the chip with 8/20 μ s waveform and 1A pulse current.
E	Capacitance Tolerance. Capacitance Tolerance, M= $\pm 20\%$.
F	Dissipation Factor.
G	Temperature Characteristic. -30 $^\circ$ C ~ +85 $^\circ$ C.

◆ General Technical Data

Operating Temperature	-40 ~ +85 $^\circ$ C
Storage Temperature (on board)	-40 ~ +85 $^\circ$ C
Response Time	<1 ns
Solderability	245 $\pm 5^\circ$ C, 3 ± 1 sec.

◆ Environmental Performance

Item	Specifications	Test Condition
Bias Humidity	(1) $I_L \leq 15 \mu A$ at Working Voltage (2) $\Delta C_p / C_p \leq \pm 10\%$ (3) Solder Wetting Area $\geq 95\%$	90%RH, 40 $^\circ$ C, Working Voltage, 1000 hrs
Thermal Shock		-40 $^\circ$ C to 85 $^\circ$ C, 30 min. cycle, 5 cycles
Full Load Voltage		Working Voltage, 85 $^\circ$ C, 1000 hrs
Solder Leach Resistance		260 $\pm 5^\circ$ C, 10 ± 1 sec.

◆ Package

Size EIA (EIAJ)	0402 (1005)	0603 (1608)
Standard Packing Quantity (pcs / reel)	10,000	4,000